

# MINIDUMPERS

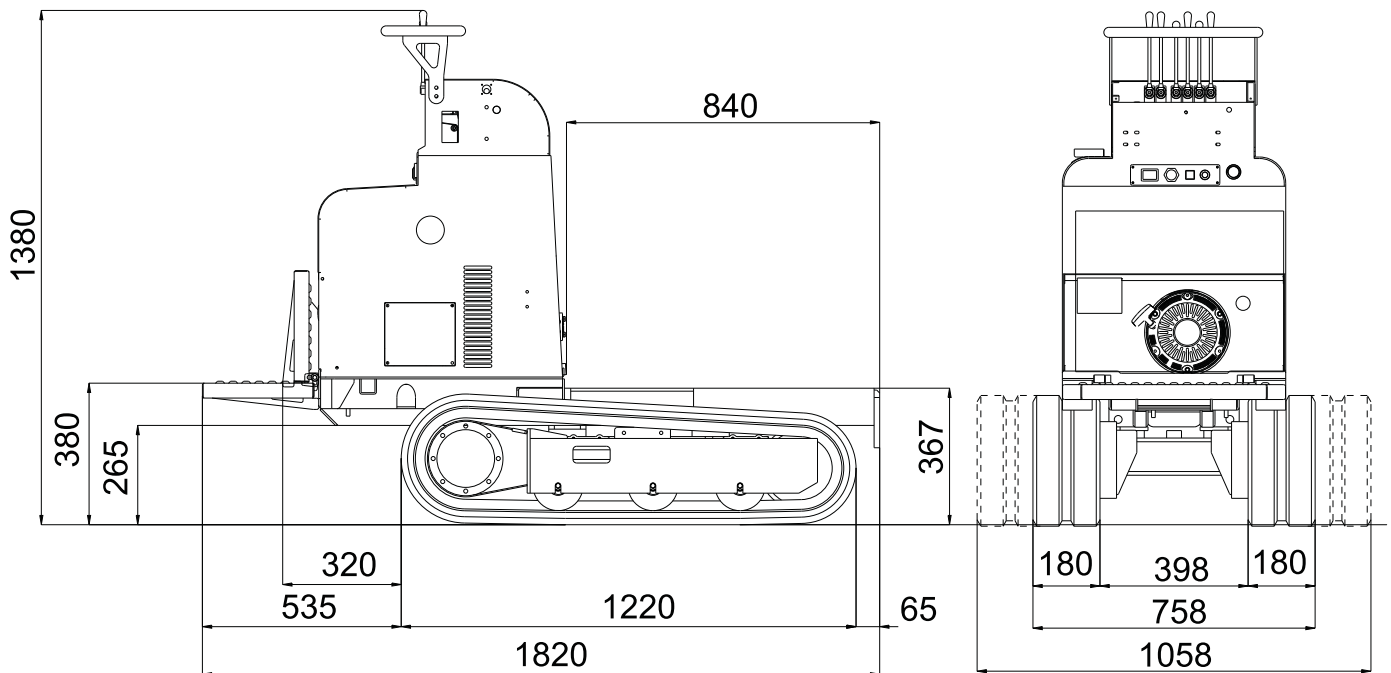

## HS1100 PETROL TRACK





# MINIDUMPERS

## HS1100 PETROL TRACK

### PETROL ENGINE

Brand ..... Honda  
 Type ..... GX390  
 Pistons and displacement ..... Single-cylinder 389 cc  
 Max gross power @ rpm..... 11,7 HP - 8,7 kw @ 3600 rpm  
 Max gross power ..... 3500 rpm  
 Electric start .....12 V  
 Performance ..... Max inclination 20° (approx. 36,4%)

### DISTRIBUTOR

Type ..... Mechanical

### HYDRAULIC PUMPS

Number and type ..... n° 3 gear pumps at 5 cc  
 Liters/min capacity .....16 l/min  
 Pressure ..... 155 bar P1-P2 / 140 bar P3

### DRIVE MOTORS

Type ..... Orbital  
 Displacement ..... 65 cc

### TRACKS

Track tensioner ..... Grease track tensioner  
 Brand ..... BRIDGESTONE  
 Dimensions ..... 180 x 72 x 37 mm  
 Rollers per side ..... 3 + slide  
 Translation speed ..... 2,6 - 4,0 km/h  
 Fixed undercarriage (optional with widening) ..... 758 / 1058 mm

**CAPACITY** ..... 1100 kg

### OPERATING WEIGHT FIXED/WIDENING UNDERCARRIAGE

(without operator)..... 480 / 570 kg

**PETROL FUEL TANK** ..... 6,5 liters

# MINIDUMPERS



## HS1100 DIESEL TRACK

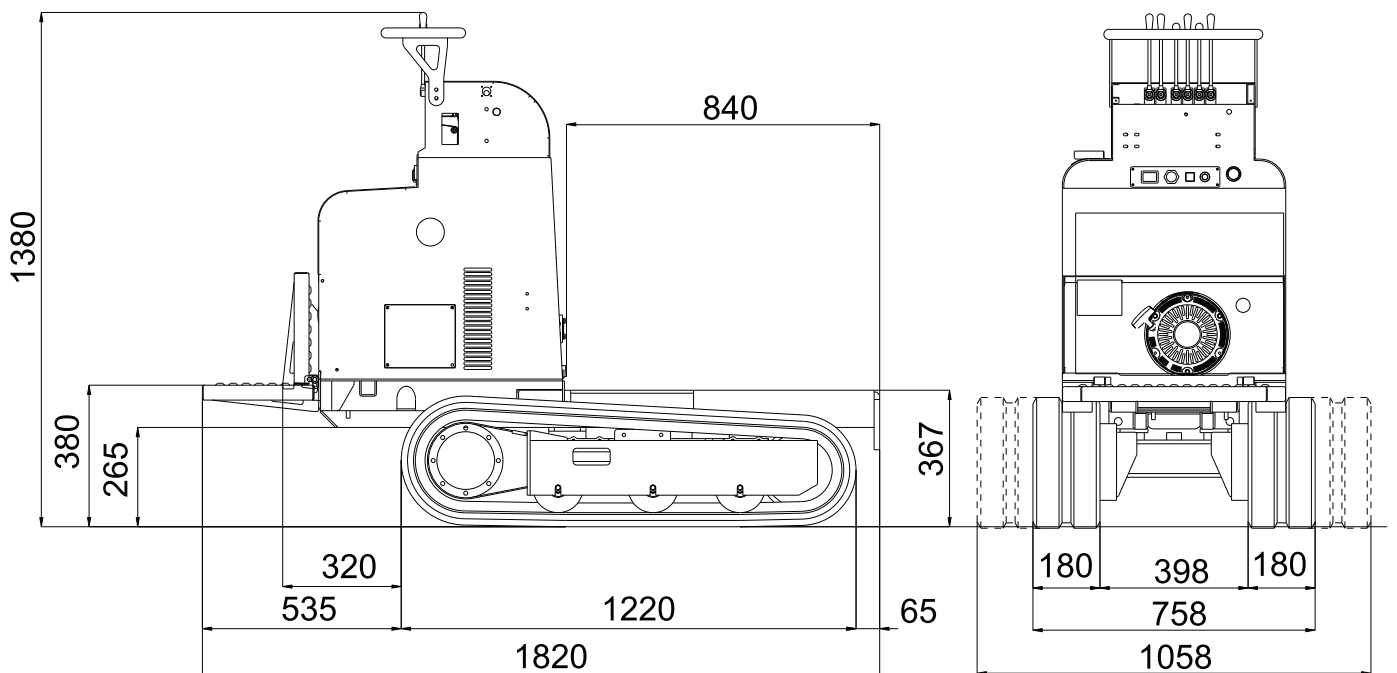



# MINIDUMPERS

## HS1100 DIESEL TRACK

### DIESEL ENGINE

Brand ..... YANMAR  
Type ..... L100N  
Pistons and displacement ..... cylinder 406 cc  
Max gross power @ rpm ..... 10 HP - 7,4 kw @ 3600 rpm  
Max gross power ..... 3000 rpm  
Electric start ..... 12 V  
Performance ..... Max inclination 20° (approx. 36,4%)

### DISTRIBUTOR

Type ..... Mechanical

### HYDRAULIC PUMPS

Number and type..... n° 3 gear pumps at 5 cc  
Liters/min capacity .....16 l/min  
Pressure ..... 155 bar P1-P2 / 140 bar P3

### DRIVE MOTORS

Type ..... Orbital  
Displacement ..... 65 cc

### TRACKS

Track tensioner ..... Grease track tensioner  
Brand ..... BRIDGESTONE  
Dimensions ..... 180 x 72 x 37 mm  
Rollers per side ..... 3 + slide  
Translation speed ..... 2,6 - 4,0 km/h  
Fixed undercarriage (optional with widening) ..... 758 / 1058 mm

**CAPACITY** ..... 1100 kg

### OPERATING WEIGHT FIXED/WIDENING UNDERCARRIAGE

(without operator) ..... 510 / 600 kg

**FUEL TANK** ..... 5,5 liters